

Applications

Lifting of closed steel drums – full or empty – in vertical position and with diameter 400 to 600 mm.

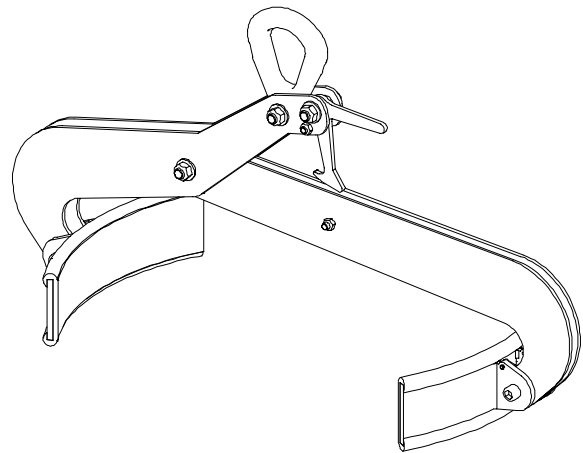
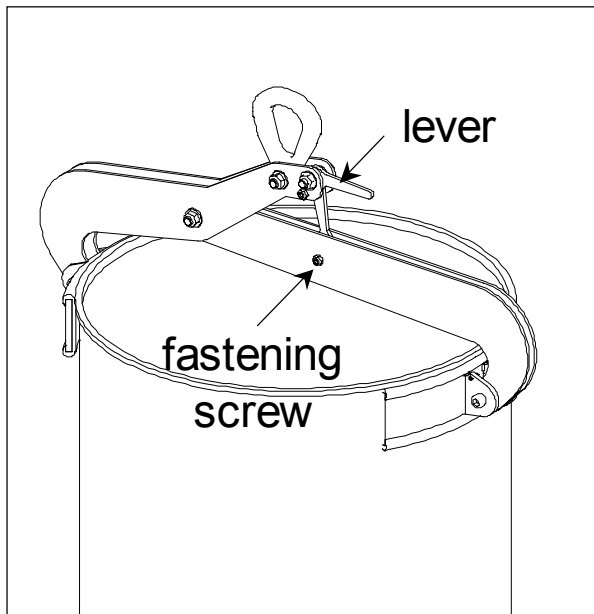

Description

Accessory equipped with an open position locking system allowing to lay down the drum without any manual intervention. Rubber coated pads ensure a great adherence and avoid marring the drums. Clamping is proportional to the load, thus minimising the drum's damage risk.

Functioning

Place the clamp locked in the open position over the drum. Lift up the lever, while starting off the lift and hold it up to prevent it from locking again against the fastening screw. When laying down, the clamp automatically locks itself in the open position.

Particular instructions

- Ensure the pads are free from grease or oil.
- Never lift greasy or oily drums.
- Not suitable for plastic drums.
- Never lift drums with sizes exceeding the opening capacity of the clamp used.
- Drum deformation risk in case of open drum lifting (without lid).
- Working temperature: -20° to +90°C.

General characteristics

- Manufacture without load bearing welds.
- Hot epoxy coating.
- Safety factor: 4 in accordance with the European Materials Handling Federation (1998 FEM 3rd edition) ; working group A5 and lifting speed 60 m/ mn.

Dimensional characteristics

Ref.	Group code	WLL kg	Drum Ø	A		B		C		D		E	F	G	H	I	J	K	Weight kg
				min	max	min	max	min	max	min	max								
VFR05-5	51248	500	400-500	297	405	673	725	110	120	115	152	80	64	23	20	62	96	270	12
VFR05-6	51258	500	500-600	327	443	767	824	110	120	115	147	80	64	23	20	62	96	320	14

Dimensions in mm

